

Engineering Specification

Model No : DC8016-000G

Customer: Standard

Part No: SPEC-DC8016-000G

Revision: 1

Engineer: Sand Wu



AcBel Product Specification

Acbel Part No.	DC8016-000G
Model Name	QB48-12-150
Description	DC-DC Converter 48Vdc Input, 12Vdc Output, 150W Output Power, Positive Logic
Revision	Rev 1
Date Issued	11/17/2009

High Output Power, High Efficiency Quarter Brick, DC8016-000G QB48-12-150

**Module: 36Vdc to 75Vdc Input,
12Vdc Output, Output Power Up to 150W**

**World's Most Advanced High Power
Density DC-DC Converters.**



DESCRIPTION:

Quarter Brick modules are DC-DC converter designed for use in distributed power architectures, workstations, EDP equipment and telecommunications. The Quarter Brick modules may be used as form, fit and function replacements for industry standard Quarter brick modules. All use planar transformer and surface mount constructions to produce up to 150W in a Quarter brick package.

OPTIONS

- Remote On/Off Logic Configuration

FEATURES:

- Industry Standard Quarter Brick:
57.9mm x 36.8mm x 12.7mm
(2.28in. x 1.45in. x 0.50in.)(Typical)
- High Power Density: Up to 90W/in.³
- High Efficiency: 92.5% Typical
- Low Output Noise
- Metal Baseplate
- Thermal Protection
- Input Under Voltage Protection
- Output Over Voltage Protection
- Current Limit/Short Circuit Protection
- Adjustable Output Voltage: 90% to 110% of $V_{o,set}$
- Remote Sense
- Remote ON/OFF Control: Positive Logic
- RoHS Compliant

SPECIFICATIONS:
ABSOLUTE MAXIMUM RATINGS

PARAMETER	MIN	TYP	MAX	UNITS	CONDITIONS
Input Voltage (+In to -In)	-0.3		100	V	<100ms
	-0.3		75	V	Continuous
Logic On/Off Voltage (On/Off to -In)	-0.3		5	V	
Storage Temperature	-40		125	°C	
Storage Humidity	10		95	%	
Operating Temperature	-40		100		Temperature measure shall be taken from the baseplate (Tb).
Operating Humidity	30		95	%	

INPUT SPECIFICATIONS:

PARAMETER	MIN	TYP	MAX	UNITS	CONDITIONS
Operation Input Voltage (Vi)	36	48	75	V	
Maximum Input Current (Ii,max)			5	A	Vi=36V, Io =Io,max
Inrush Transient			1	A ² s	
Input Reflected-Ripple Current: Peak-Peak		40	60	mA _{p-p}	5HZ to 20MHZ, Vin=48Vdc ; Io=Full Load, 12uH source impedance ; Cin=220uF ; Tb=25 degC
Input Ripple Rejection		60		dB	120Hz
Input Under Voltage Protection: Turn-on Threshold		34	36	V	Vo=12V, Io =Io,max.
Turn-off Threshold	30	32		V	
Hysteresis		2		V	

OUTPUT SPECIFICATIONS:

PARAMETER	MIN	TYP	MAX	UNITS	CONDITIONS
Output Set Point (Vo,set)	11.88	12	12.12	V	Initial Adjusted Tb=25°C, Vi=48V, Io=Io,max
Output Voltage Tolerance Band	-3		+3	%	All Operating Condition
Line Regulation			20	mV	Vi=36V to 75V
Load Regulation			20	mV	Io= Io,min to Io,max.
Temperature Drift			0.02	%/ °C	Tb= -40 to 100°C
Output Ripple and Noise Voltage Peak to Peak			120	mV _{p-p}	Bandwidth 5Hz to 20MHz and with 0.1uF MLCC. Vin=48Vdc ; Io= Full Load ; Tb=25degC ; Output Capacitor with 220uF*3EA
Output Current Io,min	0			A	At Vo<=12V, if Vo>12V, Output Power (Po) should be less than its rating power.
Io,max			12.5	A	
Output Current Limit	105		145	%Io,max	Current limit inception point Vo=90% of Vo,set
Output Short Circuit Current			20	Arms	Hiccup Mode
Output Over Voltage Protection	112		140	% Vo,set	Io=0.5A
External Capacitance		660	5000	uF	
Output Power			150	W	

OUTPUT SPECIFICATIONS (CONTINUED):

PARAMETER	MIN	TYP	MAX	UNITS	CONDITIONS
Efficiency		92.5		%	$V_i=48V, V_o=12V, I_o=80\%$ of $I_{o,max}, T_b=25^\circ C$.
Dynamic Response:		2		% $V_{o,set}$	$V_{in}=48V_{dc}; T_b=25degC$ 25% - 50% -75% load, $\Delta I_o/\Delta t=0.1A/us$; with Output Capacitor 220uF*3EA
Peak Deviation Settling Time			300	us	Duration outside of $V_{o,set}$ +/- 1.0% error band

CONTROL SPECIFICATIONS:

PARAMETER	MIN	TYP	MAX	UNITS	CONDITIONS
Logic ON/OFF Remote: Positive: Off-State Voltage On-State Voltage	2.0		0.8	V V	
Negative: Off-State Voltage On-State Voltage	2.0		0.8	V V	
Turn-On Time		40		ms	$V_o=90\%$ of $V_{o,set}$
Output Voltage Trim Range	90		110	% $V_{o,set}$	Refer to Trim Circuit.
Over Temperature Protection Shutdown Recovery	100	105 90	115	$^\circ C$ $^\circ C$	Refer to Fig.3 for location definition Auto. Recovery

ISOLATION SPECIFICATIONS:

PARAMETER	MIN	TYP	MAX	UNITS	CONDITIONS
Input to Output		1500		Vdc	60 seconds
Input to Case		1500		Vdc	60 seconds
Output to Case		500		Vdc	60 seconds
Input to Output Capacitance		2000		pF	
Isolation Resistance	100			Mohm	At $T_b=25^\circ C, 70\%RH$, Output to Baseplate 500VDC

STRUCTURAL DYNAMICS:

PARAMETER	CONDITIONS
Vibration	Sine Wave, 10-55Hz (Sweep for 1 min.), Amplitude 0.825mm Constant (Maximum 5g) X,Y,Z 1 Hour each, At No Operating,
Shock	20g, 166 in/sec, Square Wave

GENERAL SPECIFICATIONS:

PARAMETER	MIN	TYP	MAX	UNITS	CONDITIONS
MTBF		1.8		Mhrs	$T_b=40^\circ C, I_o=80\%$ of $I_{o,max}$
Weight		65		g	
Size (WxHxD)		2.28x1.45x0.50		in.^3	

TRIM CIRCUIT:

A. Trim down: The resistor for output voltage trim-down function could be calculated with the following formula:

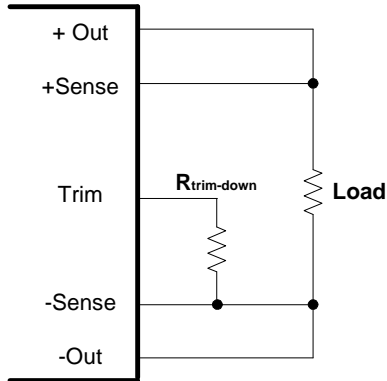

$$R_{trim-down} = \left(\frac{100\%}{\Delta\%} - 2 \right) (k\Omega)$$

$\Delta\%$: Output voltage change rate against nominal output voltage.

Fig. 1 The schematic for output voltage trim down.

B. Trim up: The resistor for output voltage trim-up function could be calculated with the following formula

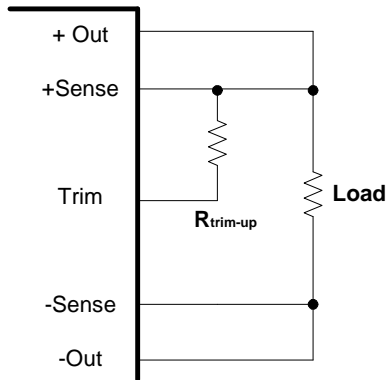

$$R_{trim-up} = \left[\frac{V_o(100\% + \Delta\%)}{1.225\Delta\%} - \frac{(100\% + 2\Delta\%)}{\Delta\%} \right] (k\Omega)$$

V_o : The nominal output voltage.

$\Delta\%$: Output voltage change rate against nominal output voltage.

Fig. 2 The schematic for output voltage trim up.

BASEPLATE MEASURE POINT:

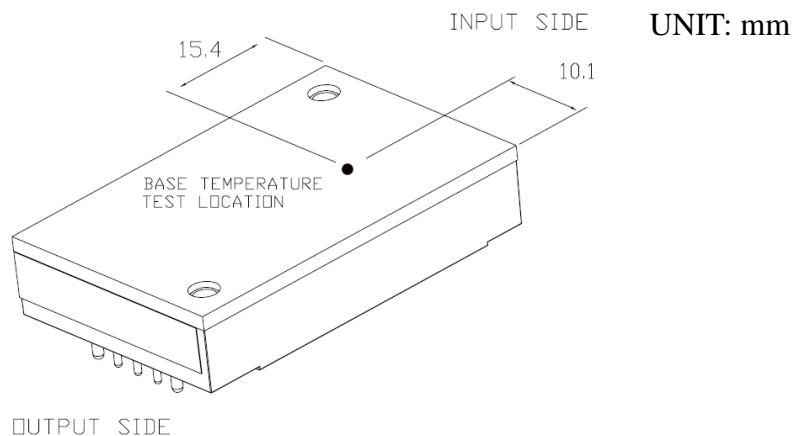
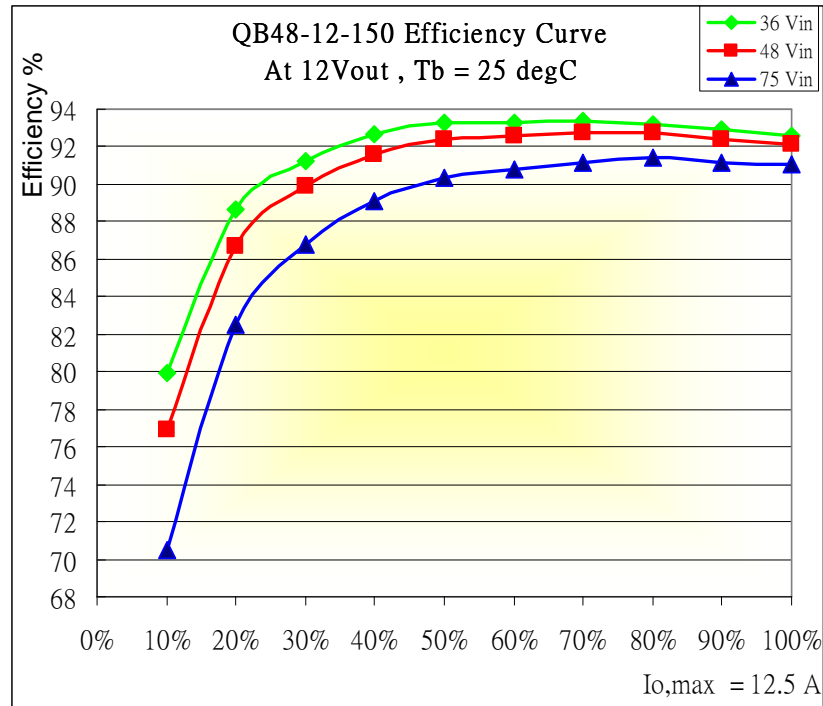

Fig. 3 Baseplate Temperature Measure Point.

EFFICIENCY CURVE :



DERATING CURVE:

Output Power (%)

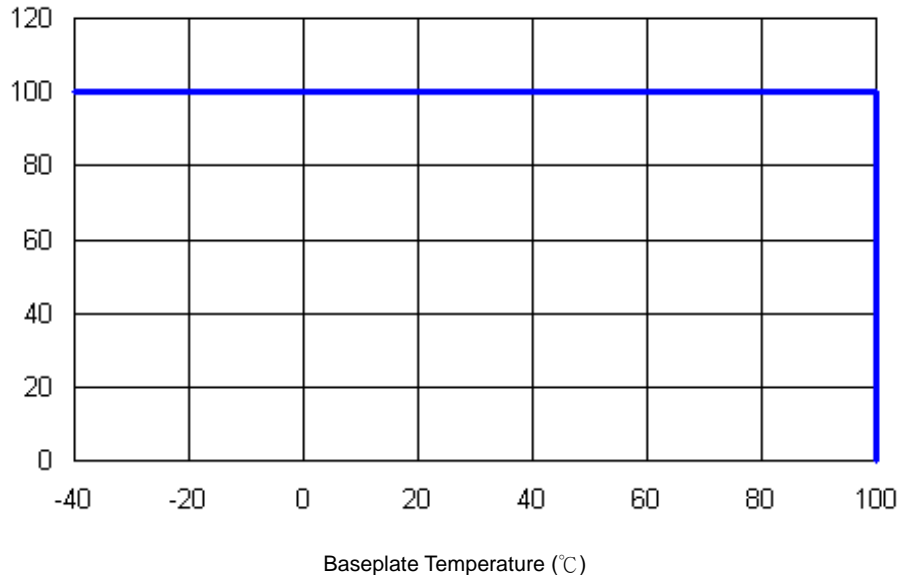

OUTLINE DRAWING:

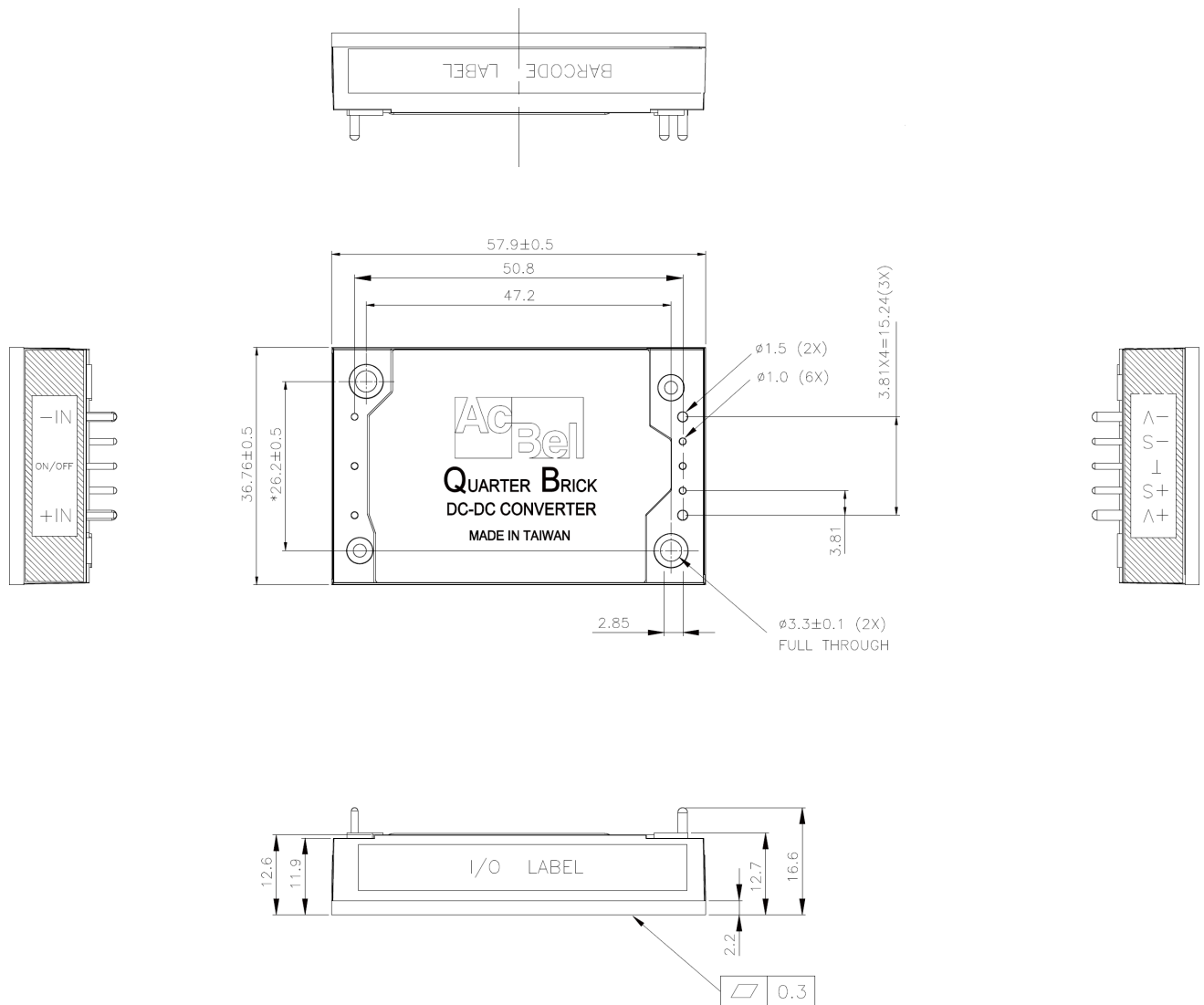

OUTLINE PIN ASSIGNMENT:

Pin Number	Signal name
1	Input (-)
2	On/Off Control
3	Input (+)
4	Output (+)
5	Sense (+)
6	Trim
7	Sense (-)
8	Output (-)

